

# ATV / UTV Auto-Winch Stop Kit

Product Instructions | Part No: 25-0600 / 25-0650

**Application:** Verify accessory fitment at Kolpin.com.

**Before You Begin:** Read these instructions and check to be sure all parts and tools are accounted for. Please retain these installation instructions for future reference and parts ordering information.

**Note:** If any hardware is missing, do not return to the store. Call us to help, Toll Free 1-877-956-5746.

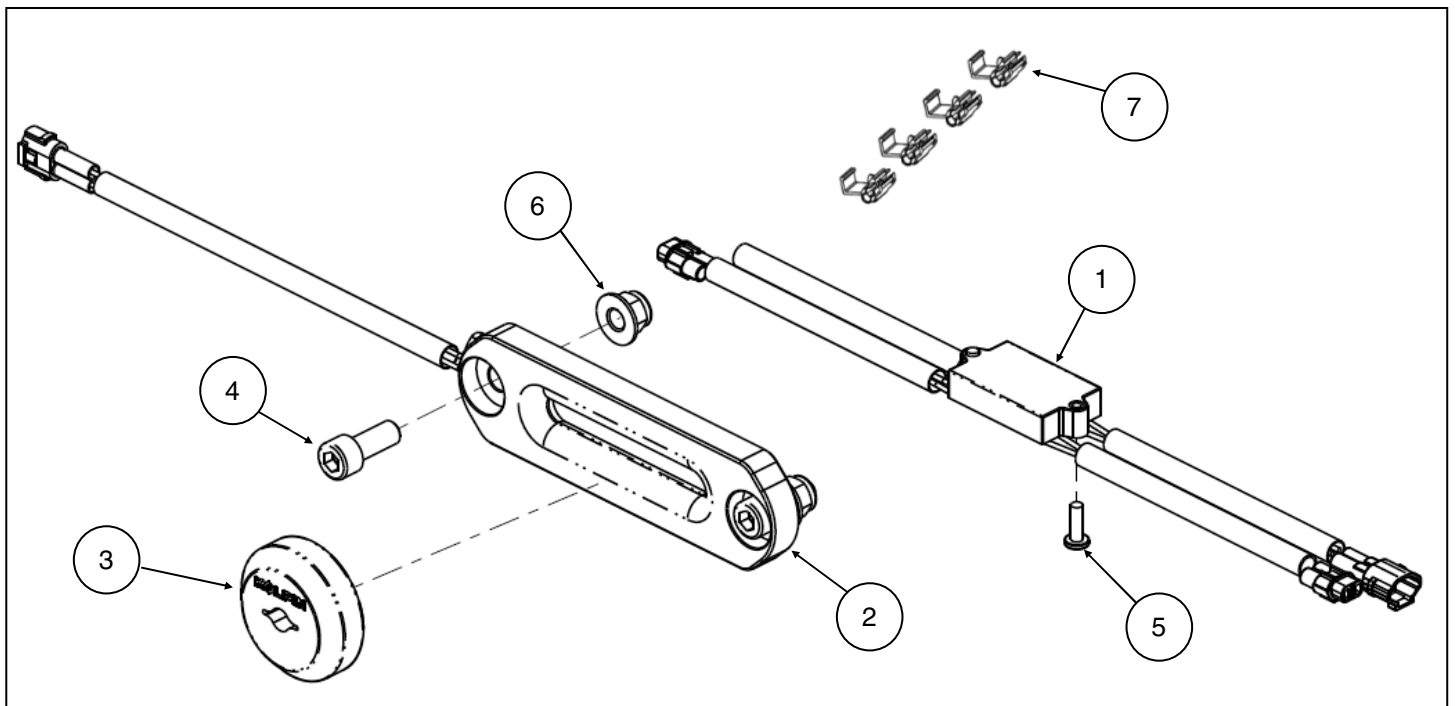

**This Kit includes:**

Item	Qty	Part Description	Part Number
1	1	Control Box, Hawse Fairlead	2413444
2	1	Narrow Hawse Fairlead (PN 25-0600)	-
	1	Wide Hawse Fairlead (PN 25-0650)	-
3	1	Rubber Bumper Magnet Stop	5415787
4	2	Socket Head Cap Screw, Zinc Plated, M10 - 1.5 x 25mm LG	-
5	2	Button Screw, Zinc Plated, #10 x 3/4" LG, T25 Torx Drive	-
6	2	Flange Locknut, Zinc Plated, M10 - 1.5	-
7	4	Scotch Lock Splice Connector	-
8	1	Instruction Guide (not shown)	-

**Note:** Depending on vehicle application, extra wire and/or hardware may be necessary.

## Tools Required:

- Safety Glasses
- 13mm Socket and Ratchet
- Pliers
- 7/16" (11.00mm) Drill Bit and Electric Drill - depending on vehicle install
- T-25 Torx Driver
- 8mm Allen Wrench
- Wire Cutters

**Assembly Time:** Approximately 60 minutes

**Important:** Your Kolpin Auto-Winch Stop Kit is universally designed for your vehicle. Please read the installation instructions thoroughly before beginning. Installation is easier if the vehicle is clean and free of debris. For your safety, and to ensure a satisfactory installation, perform all installation steps correctly in the sequence shown. Additional time may be required to accommodate other installed accessories.

**Function of the Auto-Winch Stop Feature:** The Auto-Winch Stop fairlead is an innovative solution making your winch easier to use, especially when plowing. The hardest work your winch does is when it isn't doing much work at all; when your winch pulls the rope tight to get the last bit of lift out of the plow or to tighten up the hook to prevent it from rattling against the bumper. As the winch pulls the hook against the fairlead it stresses the winch, rope, fairlead, and vehicle frame. To help prevent damage to these components, Kolpin created a solution that stops the winch before the hook is pulled too far into the fairlead.

This auto-winch stop is only for use with synthetic rope, as a steel cable would quickly wear and damage the aluminum fairlead. If your vehicle is equipped with steel cable, you will need to order a synthetic rope. For 4500 lb. winch models, order rope kit PN 85064; for 3500/2500 lb. winch models, order rope kit PN 85065. When the rubber bump stop is brought close to the fairlead, sensors inside the fairlead tell the control box to turn the winch off. The winch will continue to let rope out, but the rope will not pull in any further.

## INSTALLATION INSTRUCTIONS:

**NOTE:** See the *Electrical Connections Reference Guide* section of the instruction manual for detailed photos of each part and their respective connections.

1. To install this kit, you will need to replace the roller fairlead with the aluminum Hawse fairlead (item #2) included with this kit, and install the control box (item #1). Both of these operations are fairly simple, but pay attention to the details described in the steps to ensure proper operation. If you are installing a wireless remote at this time, refer to the wiring diagram in this kit and use the instructions in the wireless remote kit to aid in your installation.
2. Shift vehicle transmission into "PARK" or set the parking brake. Turn ignition key to "OFF" position and remove from vehicle ignition.
3. Gain access to the battery. Disconnect black (negative) and red (positive) cables from battery as shown. Retain bolts for use during reinstallation. (See illustration 1-1).

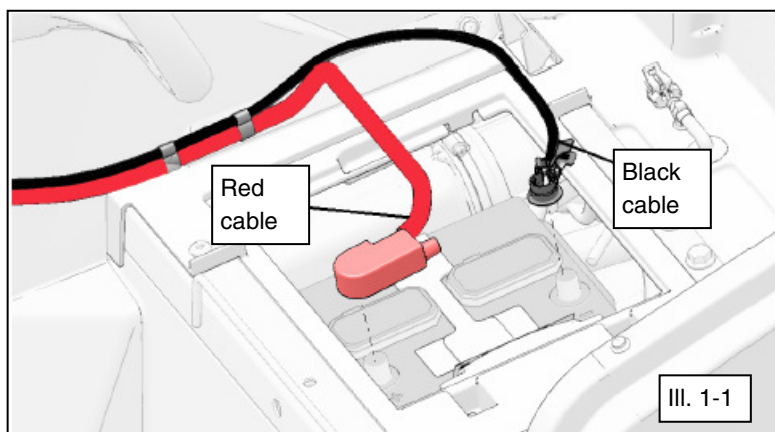



**⚠ WARNING ⚠**

**ALWAYS** disconnect black negative (-) cable from battery **FIRST**. Failure to do so will result in high current electrical arc, and may result in battery explosion if tool touches grounded frame. Death or serious injury may occur.

**INSTALLATION INSTRUCTIONS (continued):**

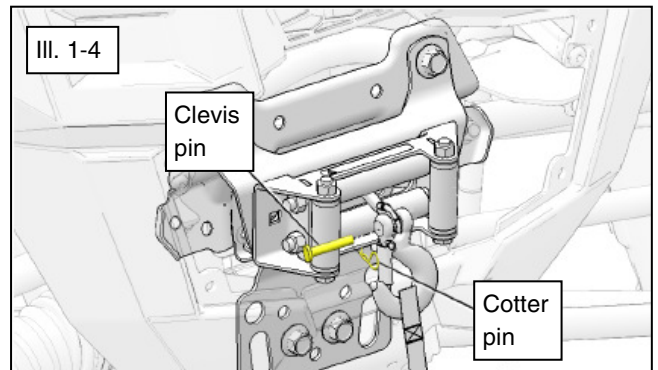
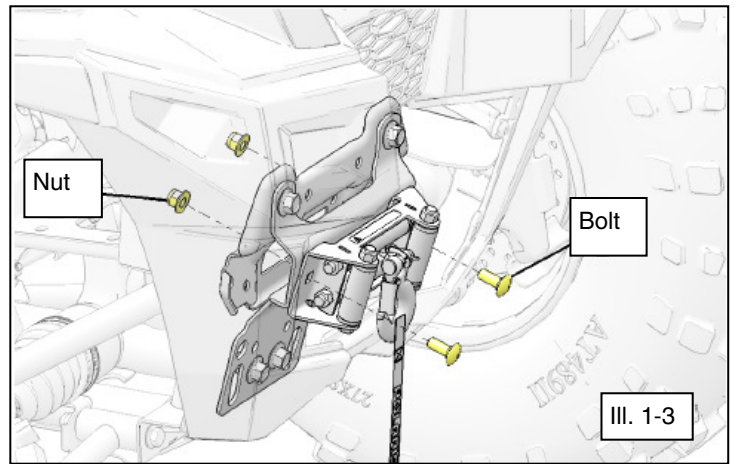
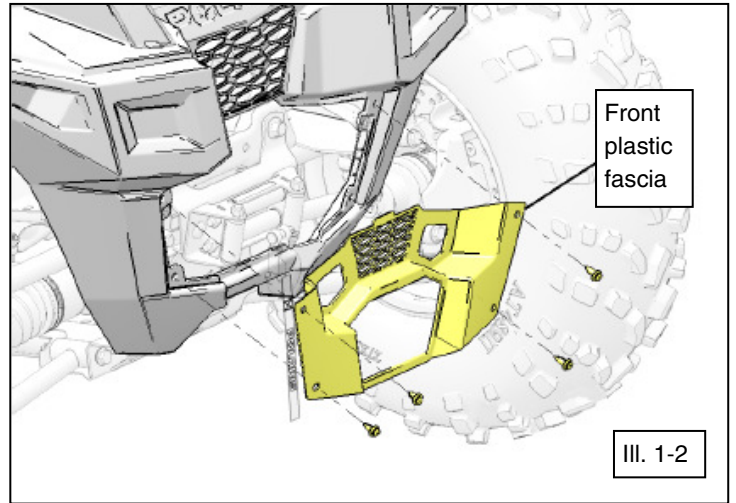
4. Detach lower front fascia as shown if required to access the fairlead. (See illustration 1-2). **Note, your vehicle may differ somewhat from illustrations shown.**
5. Remove the two nuts and bolts holding the roller fairlead onto fairlead mounting bracket as shown. (See illustration 1-3).
6. Remove the cotter pin and clevis pin from the hook as shown to allow the rope to be pulled through the fairlead. If you have a wire rope, replace it with a synthetic rope at this time. (See illustration 1-4). **Note, if your fairlead mounting bracket has two smaller bolt holes than 10mm, you will need to enlarge the holes to allow the provided M10 screws (item #4) to fit. Use a 7/16" (11.0mm) drill bit to enlarge the mounting holes.**
7. Thread the rope through the aluminum fairlead (item #2) so that the side with recessed holes for the fasteners faces away from the vehicle. Using new screw (item #4) and nut (item #6) included with this kit, install the fairlead onto the machine with the wire pointing toward the passenger side of the vehicle as shown. (See illustration 1-5).
8. Tighten fasteners to specification.



 = T
<b>10MM FASTENER TORQUE:</b> 34 ft. lbs. (46 Nm)

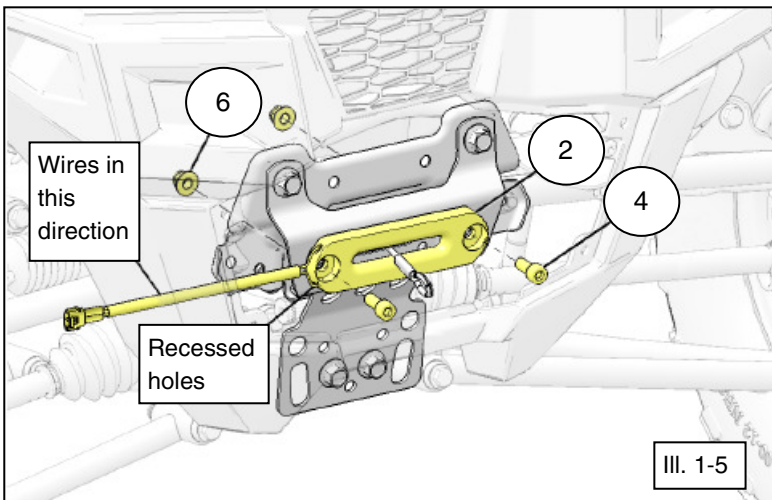

**INSTALLATION INSTRUCTIONS (continued):**

9. Thread the rope through the rubber bump stop with the "KOLPIN" label facing outward, away from the vehicle as shown. The rubber bump stop (item #3) is supposed to be tight on the rope, so use a plastic cable tie or string (not included), tied around the end of the rope to pull the rope through the bump stop. It is helpful to apply a small amount of rubbing alcohol or other non-corrosive lubricant to the rubber bump stop to ease the rope through the hole. Once the rope is through the hole, attach the hook to the rope with cotter pin and clevis as mentioned in Step 6. (See illustrations 1-6 and 1-7). **Note, the rope may need to be first removed from winch spool, then feed rope thru bumper/fairlead and back into winch spool.**

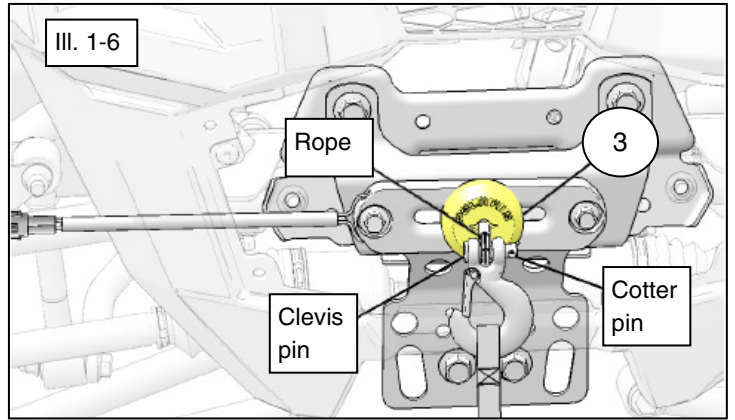

10. Connect the control box (item #1) to the Hawse fairlead (item #2). The long wire from the control box should be connected to the wires from the fairlead as shown. (See illustration 1-8).



11. Route the control box (item #1) and wires along the main harness to position it close to the contactor. Disconnect contactor from the main harness, then reconnect the control box (item #1) in between them. Refer to block diagram as shown. (See illustration 1-9). **Note, scotch lock splice connectors (item #7) are provided as optional methods of universally connecting to non-Kolpin winch harnesses.**

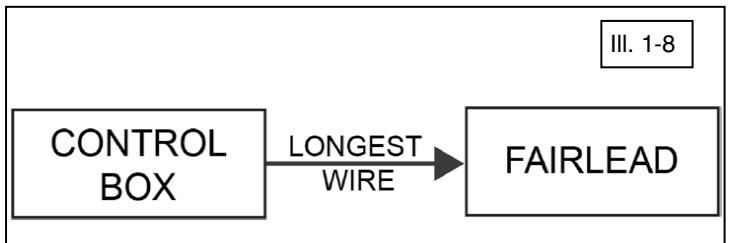

12. Secure the control box (item #1) to the frame or wire harness using cable ties (not included) or included screws (item #5). Make sure to secure in a location to avoid hot or moving parts.

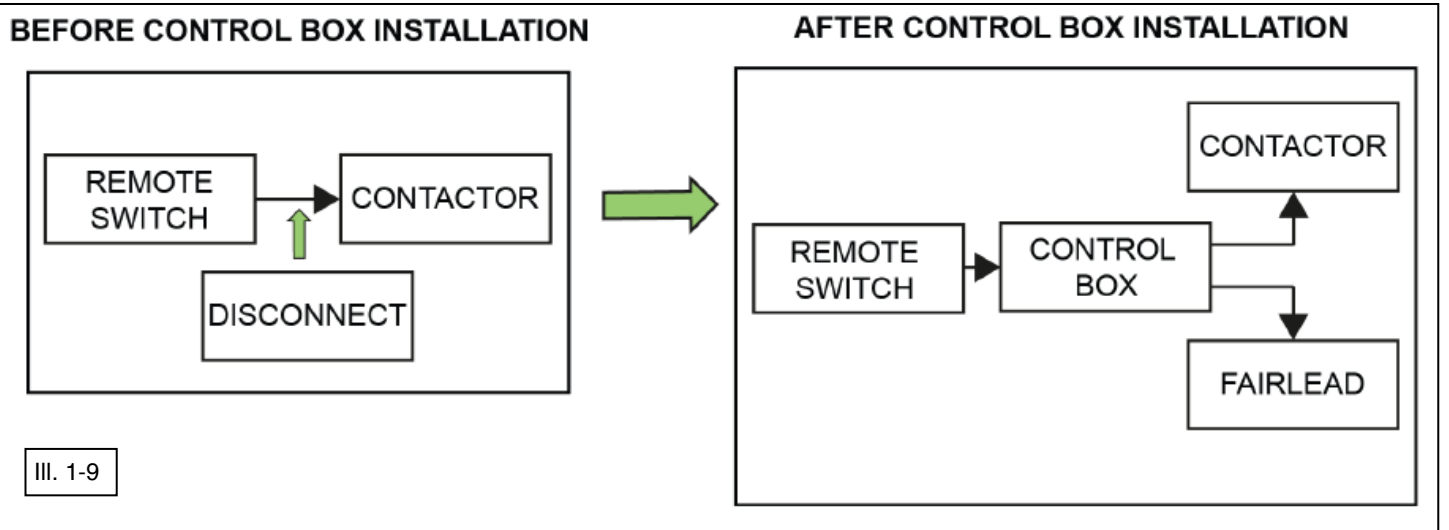



## INSTALLATION INSTRUCTIONS

### (continued):

13. Connect the control box to the appropriate power on your vehicle. For RZR and RANGER, use ring terminal connections to attach to the keyed power (orange) terminal and ground (black) terminal. For ATV, use 1/4" spade terminal to attach to the orange/white wire on the main harness underneath the front rack by the steering post. Attach the black wire to the battery or bus bar ground connection. Check and tighten all wire connections and secure any loose wires using cable ties. **Note, DO NOT**

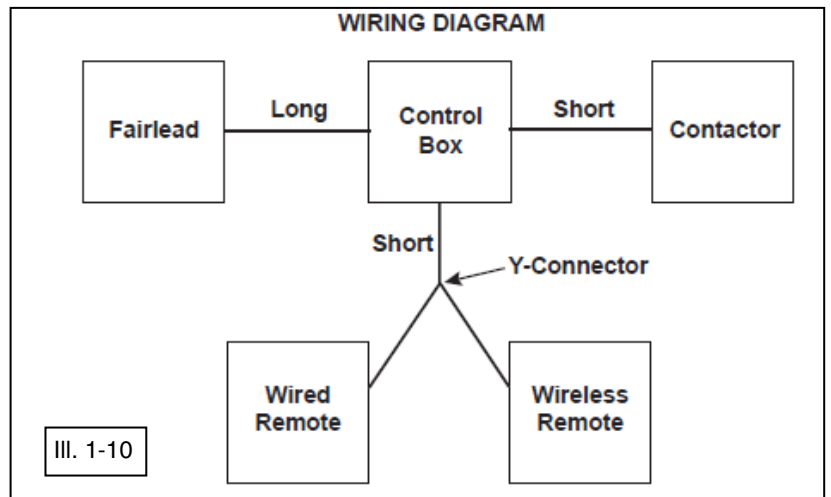

**connect orange wire to battery positive or red wire on terminal block as it will cause the battery to drain. Connect orange wire ONLY to orange keyed power wire or post.**

14. Note, if you are installing the wireless remote control kit (PN 25-0500), connect it between the vehicle wire harness and fairlead control box as shown. (See illustration 1-10).
15. Connect the other end of the fairlead control box (item #1) to the contactor.
16. Connect the fairlead (item #2) to the fairlead control box (item #1).
17. Confirm that all wiring is correct and confirm that there are no exposed wires or terminals.
18. All loose wires need to be wrapped tight, and secured away from moving parts and heat sources.
19. Re-install lower front fascia removed in step 4 using hardware previously removed.
20. Re-install red and black cables to battery terminals using OEM screws as shown.
21. With vehicle key in the ON position, check winch for proper operation.

For additional assistance, please contact Kolpin customer service department at (877) 956-5746 or (763) 478-5800 or email [customerservice@kolpin.com](mailto:customerservice@kolpin.com)

### One Year Limited Warranty

For the period of one (1) year from the purchase date, Kolpin will replace for the original purchaser, free of charge, any part or parts found upon examination by Kolpin to be defective in material, workmanship, or both.

All transportation costs incurred submitting product to Kolpin for warranty consideration must be borne by the purchaser. If Kolpin determines that the product must be returned to the factory for credit, please call 1-877-956-5746 for a Return Merchandise Authorization (RMA) number and shipping instructions.

This warranty does not apply to parts that have been damaged by accident, alteration, abuse, improper maintenance, normal wear, or other causes beyond the manufacturer's control. In order to protect you and your ATV, certain parts of the accessory system and/or hardware are designed to fail when the equipment is over-stressed. Parts that are lost due to loosening and improper maintenance are not covered under warranty. This warranty does not cover removal or reinstallation labor fees of the plow system and related components.

Peripheral products such as engines, electric motors, and actuators may carry an original manufacturer's warranty. Most hardware is general in nature and is easily obtained locally. Be sure to replace with minimum metric class 8.8 specification.

# ELECTRICAL CONNECTION REFERENCE GUIDE:

## Winch with Auto-Stop Fairlead

