



## Honda Talon Keyed Accessory Busbar

Thank you for purchasing our Plug & Play Keyed Busbar Power Out System. The Honda Talon only has a 10 AMP accessory port (Cigarette Lighter Type). For sample, a Horn uses 6 amps, a Dome light uses ½ to 1-AMP, so you can see that the accessory port is extremely limited. Adding this system gives the original 10-AMP and adds another 35-AMP circuit. So, most accessories like Horn, Turn Signals, Rock Light, Dome Lights, Grille Lights, Rear Lights and so on can be on a Plug & Play Keyed Circuit.

Please read the instructions fully and familiarize yourself with the components before starting the install.

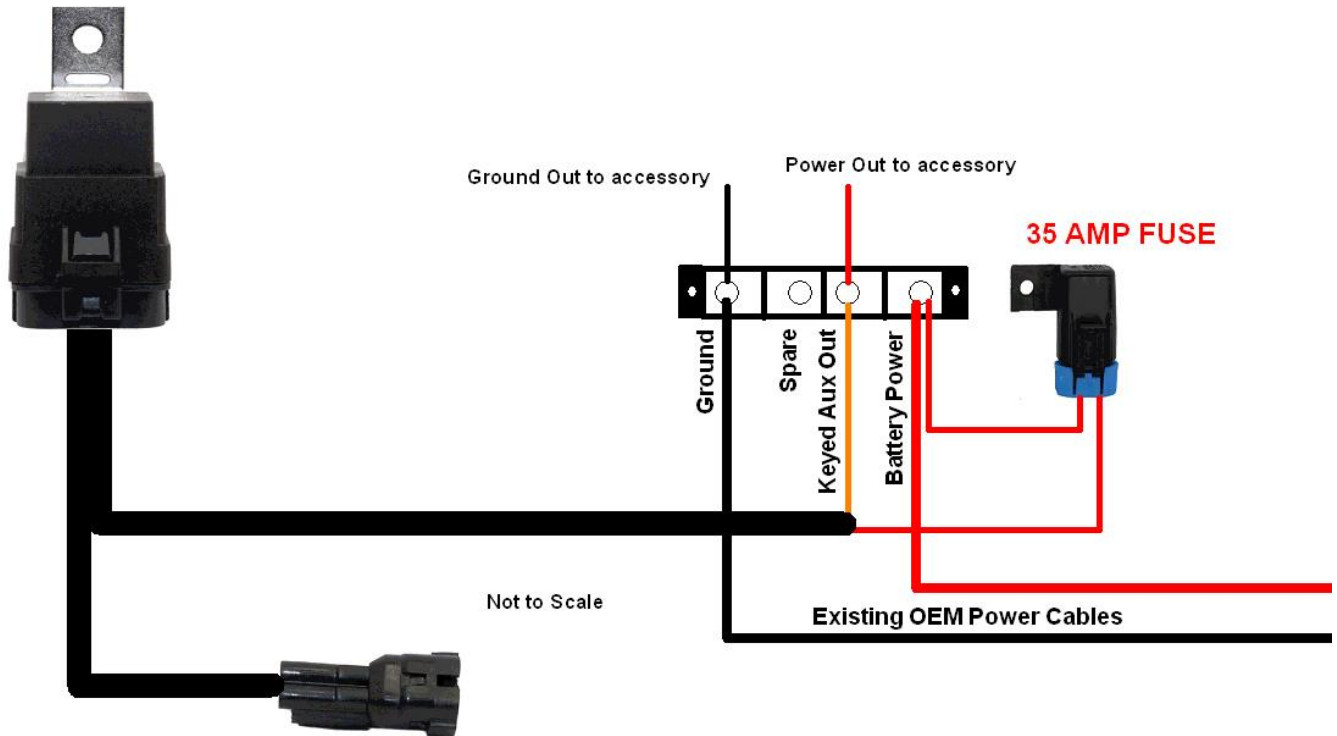
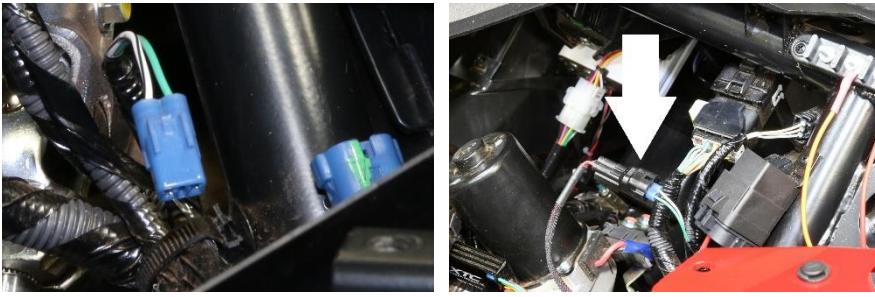

Diagram Not to Scale

Remove the hood and the Dash Cover by removing the appropriate fasteners.  
Using the provided Self Tapping Screws mount the Busbar and Relay on the Frame Rail.



Un-plug the Blue Accessory Port Connector and plug the system in. If the port is already being used, XTC offers a Power Port Splitter, part number HON-AUX-SPLIT to add a second output.



The PCS-S2-KBUS attaches to the OEM winch cable for power. The cables are cable tied on the driver's side under the dash. Remove the cables and Tape covering the cable connectors. Two pieces of Heat Shrink are provided to help protect the factory Cable. Slide the Red Shrink over the Factory Red Cable and Heat using a Heat Gun. Do the same for the Black Cable.

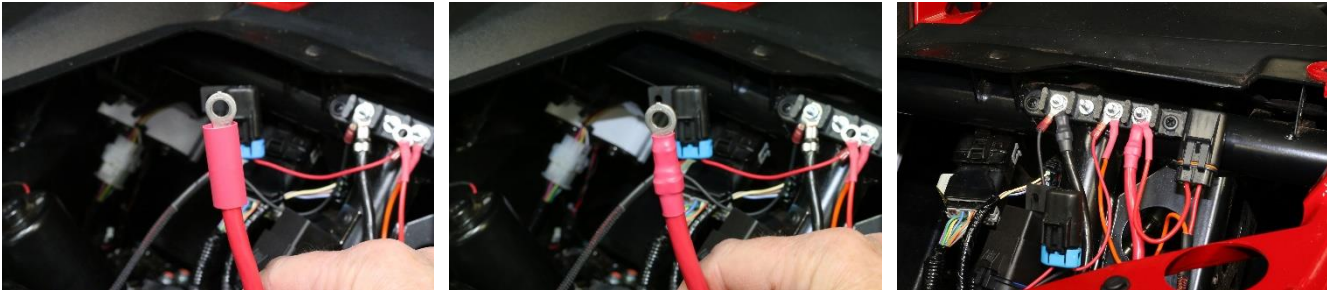

Attach the Red Cable to the right-hand post with the Red Wire, attach the Black cable to the Left-hand Post.

Attach any fused accessory power to the Orange wire and the accessory ground wire to the Black left post. There is an extra post that can be jumped to the positive or negative post for extra hookups.

At the Battery Box find the Winch cable taped to the back of the box, remove the tape and attach the winch cables to the battery per the manufacturers winch Hook-up Instructions.

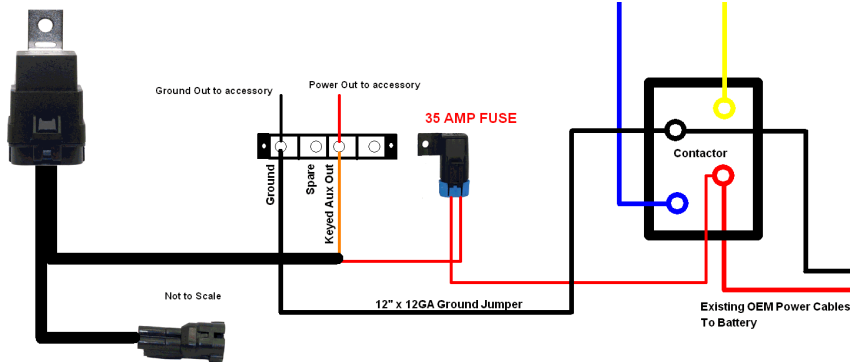

If a winch has been installed, use the provided jumper wire to go from the winch relay ground to the Busbar Ground. Attach the red wire with the fuse holder to the positive post on the winch relay.

**Only attach accessories that have their own fuse to the Systems output post, Orange Wire Post.**  
**For more details on installation go to [www.xtcinstall.com](http://www.xtcinstall.com)**

We can also be reached by email at [support@xtcpowerproducts.com](mailto:support@xtcpowerproducts.com)

XTC Power Products  
 A Division of XTC Motorsports LLC  
 925 N McQueen RD. #101  
 Gilbert AZ 85233  
 480-558-8588

[www.xtcpowerproducts.com](http://www.xtcpowerproducts.com)

\*Disclaimer: This kit is intended for off road use only and XTC Motorsports claims no responsibility for it use. It is up to the purchaser to make sure it complies with all Federal, State and Local laws.

R1

Copyright © 2020 XTC MOTORSPORTS LLC, all rights reserved.